

TECHNICAL DATASHEET

Industrial Grade Open Frame Power Supply 150W/24V BI150-240AP-R

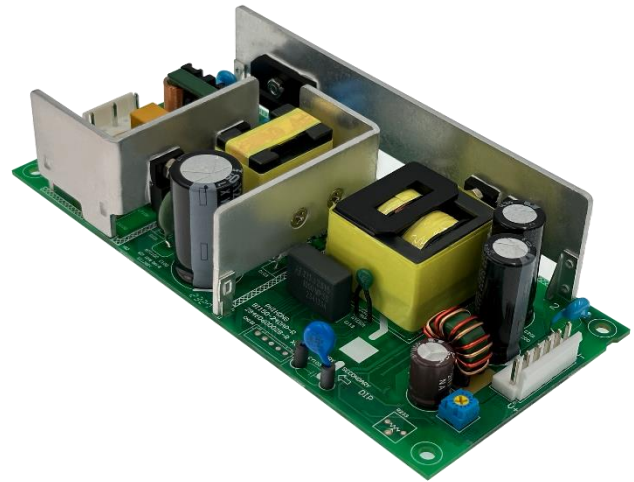

Applications

- Industrial automation machinery
- Industrial control system
- Electronic instruments, equipment, or apparatus
- Semiconductor fabrication equipment

Safety Standards



CB Certified for worldwide use / PSE Compliance

Dimensions

160 x 75 x 37 mm (6.30 x 2.95 x 1.46 inch)

Features

- Universal AC Input range (85 - 264 Vac)
 - Active Boost PFC ensures high PF and complying with Harmonic current EN 61000-3-2, Class D
 - Half-Bridge ZVS topology achieves up to 91 % efficiency
 - -10 to 70 °C ultra-wide operation range at convention cooling
 - Conformal coating on PCBA to be against moisture, dust, and chemical pollutants
 - Design compliance with EMI EN 55032, EMS EN 55035, safety EN/UL 62368-1, and RoHS Directive
 - Operation altitude up to 5000 meters.
 - 5 years warranty(with conditions)

Scopes

This industry grade of Open Frame Power Supply can operate in universal AC input from 85 to 264 Vac with lower inrush current. The built-in active Boost PFC ensures high PF and complying with Harmonic Current Emission EN 61000-3-2 class D. Embedded Half-Bridge ZVS topology enhances conversion efficiency up to 91%. Moreover, ultra-wide temperature of -10 to 70 °C, conformal coating on the PCBAs against moisture, dust and chemical pollutants, long life and only recognized Japanese capacitor usage makes it robust in a variety of critical application environments. Besides, it is featured with Power Boost of 200% for 10 seconds enables reliable startup of high surge current scenarios as capacitive or motoring loadings without increasing budget for selecting higher power rating.

This product is certified for EMI standard according to EN 55032, EMS standard according to EN 55035, and major international safety standards according to EN/UL 62368-1 and is fully compliant with RoHS Directive for environmental protection.

Specifications

AC Input Characteristics

Nominal Input Voltage	100-240 Vac
Input Voltage Range	85-264 Vac
Nominal Input Frequency	50-60 Hz
Input Frequency Range	47-63 Hz
DC Input Voltage Range	120-370 Vdc
Input Current	< 1.6 A @ 115 Vac, < 0.9 A @ 230 Vac (100% load)
Efficiency	90% typ. @ 115 Vac, 91% typ. @ 230 Vac (100% load)
No-load Power Dissipation	< 1.5 W @ 115 / 230 Vac
Max Inrush Current at Cold Start	< 30 A @ 115 Vac, < 60 A @ 230 Vac
Power Factor	> 0.9 @ 115 / 230 Vac (100% load)
Leakage Current	< 300 uA @ 115 / 230 Vac

DC Output Characteristics

Nominal Output Voltage	24 Vdc
Output Voltage Adjustment Range	21.6-26.4 Vdc
Rated Output Current	6.3 A
Minimum Output Current	0 A
Peak Output Current	12.6A (Power Boost for maximum 10 seconds)
Output Power	150 W (while output voltage $\leq 24V$, current derating needed while output voltage $> 24V$ to keep total power at 150W) 300 W (Power Boost for maximum 10 seconds. For repetitive operation, average power shall not exceed continuous 150W rating)
Line Regulation	± 0.5 %
Load Regulation	± 1 %
Ripple and Noise (20 MHz)	< 150 mVpp @ $> 0^{\circ}C$ to $50^{\circ}C$ < 180 mVpp @ $-10^{\circ}C$ to $0^{\circ}C$
Start-up Time	< 0.5 second @ 115 / 230 Vac (100% load)
Hold-up Time	20 ms typ. @ 115 / 230 Vac (100% load)
Overshoot & Undershoot at Dynamic Response	± 5 % @ 0-50% load and 50-100% load (Slew Rate: 0.1 A/ μ S)
Capacitive Loading	4,000 μ F Max

Protections

Over Current Protection	Auto-Recovery mode after fault condition is removed
Short Circuit Protection	Auto-Recovery mode after fault condition is removed
Over Voltage Protection	27.6-33.6 V, Latch off Mode. Recycle AC ON/OFF is necessary to recover.
Over Temperature Protection	Latch Off Mode. Recycle AC ON/OFF is necessary to recover.

Environment

Operating Temperature Range	-10 °C to +70 °C
Storage Temperature Range	-25 °C to +85 °C
Power De-rating	Convection >50 °C de-rate power by 2% / °C
	Forced Cooling at 10CFM >60 °C de-rate power by 2% / °C
	< 90Vac de-rate power by 2% / V
Operating Humidity	5 to 95% RH (Non-Condensing)
Operating Altitude	0 to 5,000 Meters (16,400 ft)

Reliability

MTBF	>200,000 hrs. as per JEITA RCR-9102B
Expected Capacitor Life time	10 years (115 Vac, 50% load @ 40 °C)
Shock Test (Non-Operating)	IEC 60068-2-27, Half Sine Wave: 20 G for a duration of 11ms, 3 shocks for each 3 directions
Vibration (Operating)	IEC 60068-2-6, Sine Wave: 10 Hz to 55 Hz @ 19.6 m/S ² (2 G peak); 3 min per cycle, 60 min per axis for all X, Y, Z directions

Safety Standards

Electrical Safety	TUV Bauart	EN 62368-1
	UL/cUL recognized	UL 62368-1
	PSE Compliance	Design to meet DENAN at 100Vac - 240Vac
	CB scheme	IEC 62368-1
CE	In conformance with EMC Directive 2014/30/EU and Low Voltage Directive 2014/35/EU	
UKCA	In conformance with Electromagnetic Compatibility Regulations 2016 and Electrical Equipment (Safety) Regulations 2016	
Hi-Pot Test	Input to Output	3000 Vac / 10 mA / 1 minutes
	Input to Ground	2000 Vac / 10 mA / 1 minutes
	Output to Ground	500 Vac / 10 mA / 1 minutes

EMC

Emission (CE&RE)	CISPR 32, EN/BS EN 55032, FCC 47: Class B	
Harmonic Current Emission	IEC/EN/BS EN 61000-3-2, Class A and Class D	
Voltage Fluctuation and Flicker	IEC/EN/ BS EN 61000-3-3	
Immunity	EN/BS EN 55035	
Electrostatic Discharge	IEC 61000-4-2	Level 4 Criteria A Air Discharge: 15 kV Contact Discharge: 8 kV
Radiated Field	IEC 61000-4-3	Level 3 Criteria A 80 MHz – 1 GHz, 10 V/M with 1 kHz tone / 80% modulation

Electrical Fast Transient / Burst	IEC 61000-4-4	Level 3 Criteria A 4 kV	
Surge	IEC 61000-4-5	Level 3 Criteria A Line/Neutral to Ground:2 kV Line to Neutral:1 kV	
Conducted	IEC 61000-4-6	Level 3 Criteria A 150 kHz - 80 MHz, 10 Vrms	
Power Frequency Magnetic Fields	IEC 61000-4-8	Criteria A Magnetic field strength 30 A/Meter	
Voltage Dips	IEC 61000-4-11		
Voltage Sag SEMI F47 - 0706	80% of 200 Vac	160 Vac, 1000 ms	Criteria A
	70% of 200 Vac	140 Vac, 500 ms	Criteria A
	50% of 200 Vac	100 Vac, 200 ms	Criteria A

Mechanical

Dimensions	160 x 75 x 37 mm (6.30 x 2.95 x 1.46 inch)		
Weight	0.29 kg (0.64 lb)		
	JST	JWT	
Input Connector	B3P5-VH(LF)(SN)	A3963WV2-5P-A	
Output Connector	B6P-VH(LF)(SN)	A3963WV2-6P	
Acoustic Noise	Sound Pressure Level (SPL) < 25 dBA (1 Meter from power supply)		

Block Diagram

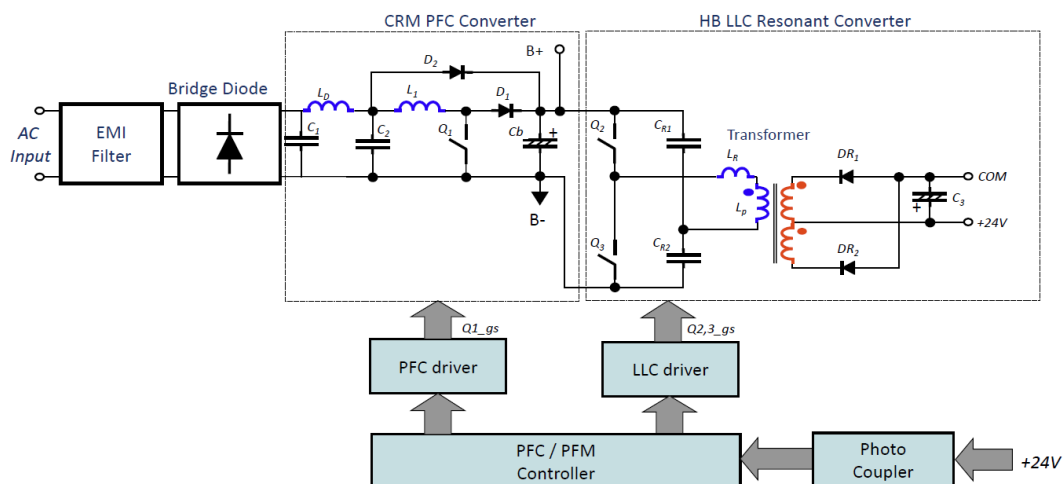

Note: Block Diagram for CRM PFC +- HB-LLC

Dimensions

L x W x H: 160 x 75 x 37 mm [6.30 x 2.95 x 1.46 inch]

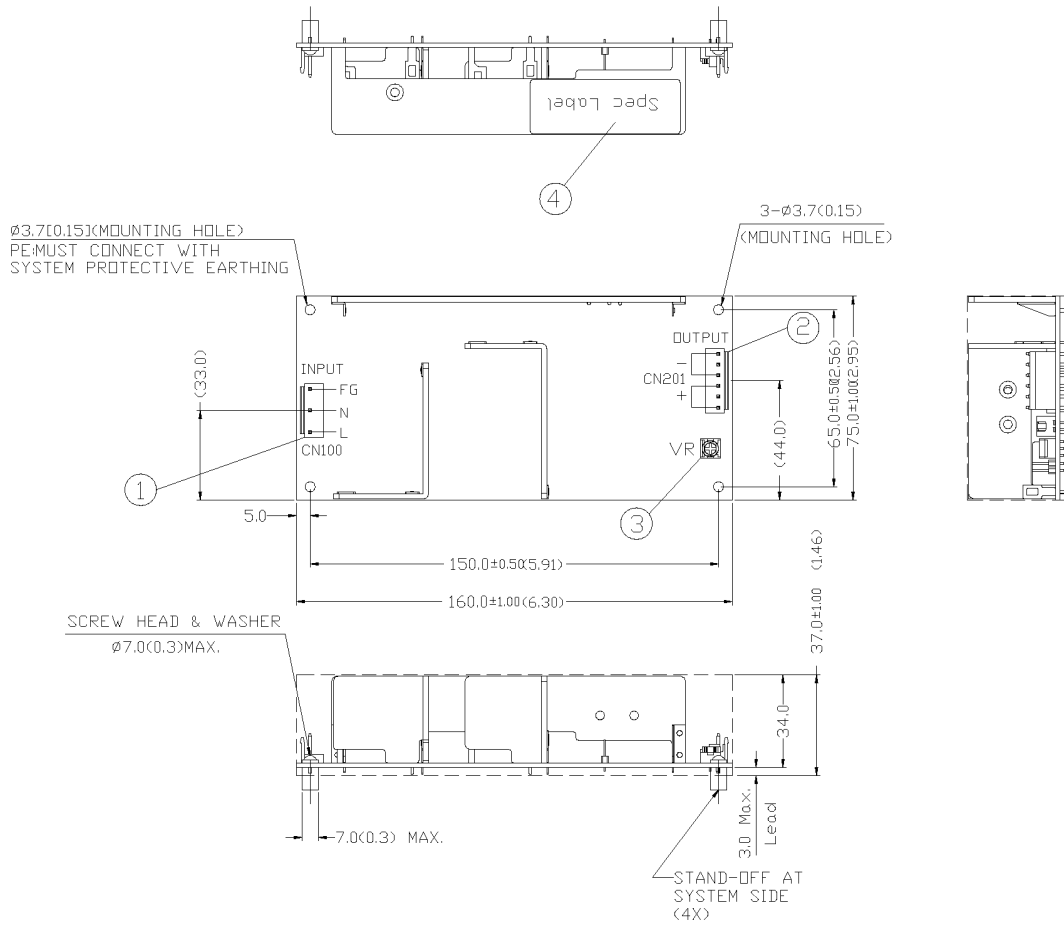

Item Device Description

Item	Device Description
1	Input Connector (CN100)
2	Output Connector (CN201)
3	VR
4	Spec Label

Notes

- Dimensions are in mm [inch]
- For information on Mounting Torque, and I/O Connector and Housing, please refer to the Instruction Manual.

Engineering Data

Mounting Orientation

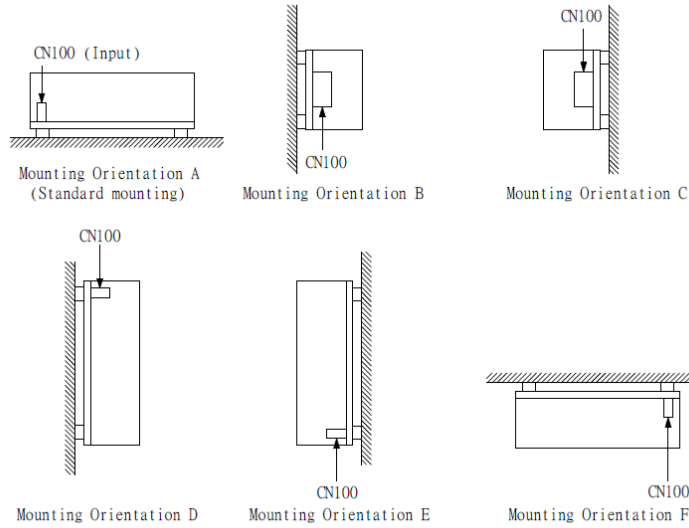

Output Load De-rating VS. Surrounding Temperature / AC Input Voltage

Condition.1 Open Frame with Surrounding Temperature. (Convictional)

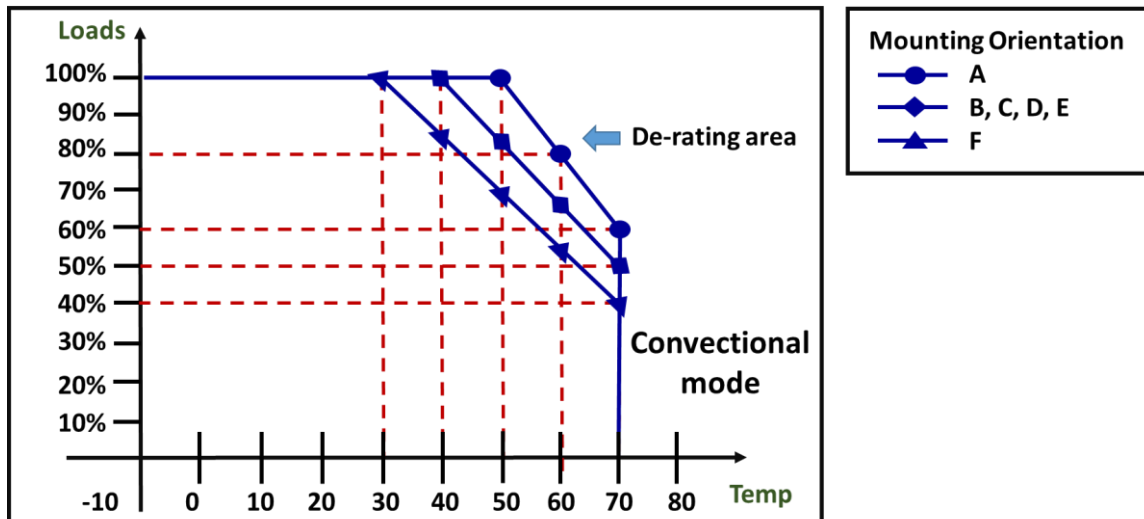

Note: De-rating Power Output with Temperature

Note

1. While surrounding temperature > 50°C, output de-rating for mounting orientation A by 2%/ °C up to 70°C.
2. While surrounding temperature > 40°C, output de-rating for mounting orientation B, C, D, E by 1.66%/ °C up to 50°C.
3. While surrounding temperature > 30°C, output de-rating for mounting orientation F by 1.5%/ °C up to 40°C.

Condition.2 Open Frame with Surrounding Temperature. (Air Forced)

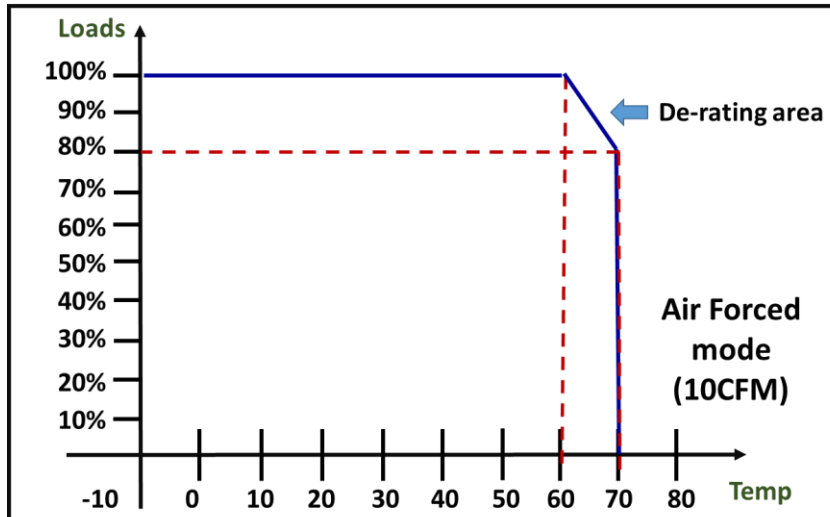

Note: De-rating Power Output with Temperature

Note

1. At air forced mode, while surrounding temperature > 60°C, output de-rating by 2%/ °C up to 70°C.

Condition.3 Open Frame with Different AC inputs

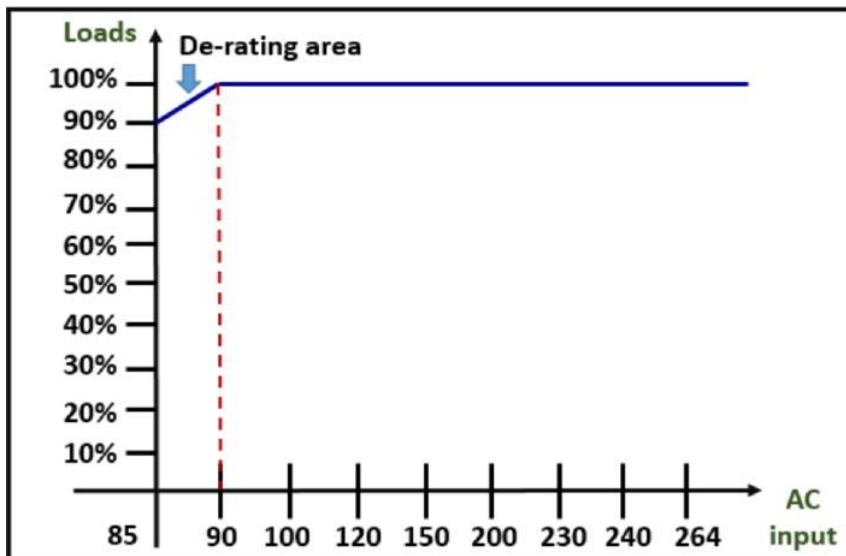

Note

1. While AC input lower than 90Vac, output de-rating by 2%/ V down to 85Vac.

Functions

Peak Power

Peak Power is the special feature for this power supply which can support peak load conditions with a higher output power rising to 200% of max. load (300W) for the maximum duration of 10 seconds. This allows enables reliable startup of high surge current scenarios as capacitive or motoring loadings without increasing budget for selecting higher power rating. This peak power can also be repetitive once the average output power shall not exceed rated 150W output.

Over Current Protection (Auto-Recovery)

While the power supply has suffered over current condition with 210% of lout of max. load, the self-protection mechanism will be activated to shut down the output and power supply then goes into “Auto-Recovery” mode. But the power supply will automatically recover once the fault condition is removed.

Short Circuit Protection (Auto-Recovery)

While a short circuit has been applied, then the self-protection mechanism will be activated to shut down the output and power supply then goes into “Auto-Recovery” mode. But the power supply will automatically recover once the fault condition is removed.

Over Voltage Protection (Latch Mode)

While an over voltage failure occurs and exceeds its specified range, the self-protection mechanism will be activated to shut down the output and power supply then goes into “Latch-Off” mode. The power supply will be resumed by the removal of over voltage condition with AC OFF/ON recycle for power supply reset.

Over Temperature Protection (Latch Mode)

While an over temperature failure occurs caused by the power supply working over its normal operating conditions or against the definitions of section of “De-rating power”, the self-protection mechanism will be activated to shut down the output and power supply then goes into “Latch-Off” mode. The power supply will be resumed by the removal of over temperature condition with AC OFF/ON recycle for power supply reset.

Others

Conformal Coating Methods



Phihong has well-designed conformal coating processes that is executed by automation equipment rather than traditional manual ways to precisely perform it without leakage to ensure coating quality for any industrial products. This can prevent power supply damage caused by dusts, moisture, or any kinds of unexpected chemical pollutants in the critical application atmosphere to achieve expected robust operation.

Phihong Locations



Headquarters Phihong Technology Co., Ltd
No. 568, Fuxing 3rd Rd., Gueishan Dist., Taoyuan City (33383), Taiwan
Tel : +886-3-3277288
Fax : +886-3-3277622
phsales@phihong.com.tw
www.phihong.com.tw



Phihong Technology Co. Ltd. (Tainan R&D Center)
No. 99, Zhengnan 1st. Street, Yongkang Dist., Tainan City 71046,
Taiwan Tel : +886-6-254-7588
Fax : +886-6-254-7288
phsales@phihong.com.tw
www.phihong.com.tw



Phihong China
Science & Technology Rd., Silver Lake Industrial Area Qingxi Town,
Dong Guan City, Guang Dong (523648), China
Tel : +86-769-87319026
Fax : +86-769-87317106
phsales@phihong.com.tw



Phihong USA
47800 Fremont Blvd., Fremont, CA 94538, U.S.A. Tel : +1-510-445-0100
Fax : +1-510-445-1678
usasales@phihongusa.com
www.phihong.com

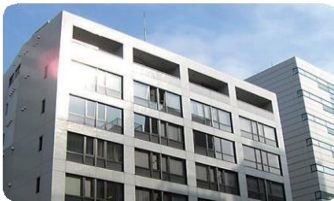

Phihong Japan
5F, VORT Toyo Bldg., 3-23-24, Toyo, Koto-ku, Tokyo, 135-0016, Japan
Tel : +81-3-5677-1678
Fax : +81-3-5634-5255
phsales@phihong.com.tw
www.phihong.co.jp



Phihong Europe
Spaces Zuidas II
Barbara Strozziilaan 201, Amsterdam, Netherlands
Tel : +31-(0)- 20-2402400
sales@phihongeu.com
www.phihong.com.tw



Phihong Vietnam
Lot CN5 An Duong Industrial Zone, Hong Phong Commune, An
Duong County, Hai Phong City, Vietnam
Tel : +84-22588-31557